

**APPLICATION:**  
 HA-8-1-4 LOW ENERGY OPERATOR  
 LEFT HAND PUSH.

**NOTE:**  
 AUTOMATIC SWING DOOR OPERATOR SHALL BE "HA-8" CETL USA APPROVED, CONFORMING TO UL STD. 325 & ANSI-BHMA STD. A156.19 CERTIFIED TO CAN. CSA STD. C22.2#247 AS MANUFACTURED BY HUNTER ACCESS TECHNOLOGIES INC.  
 32" CLEAR OPENING REQUIRED TO MEET ADA REQUIREMENT.

STANDARD FINISH: CLEAR ANODIZE, DARK BRONZE,  
 SPECIAL FINISHES ARE AVAILABLE

120V AC, 60HZ, 15A.  
 BY ELEC. CONTRACTOR.

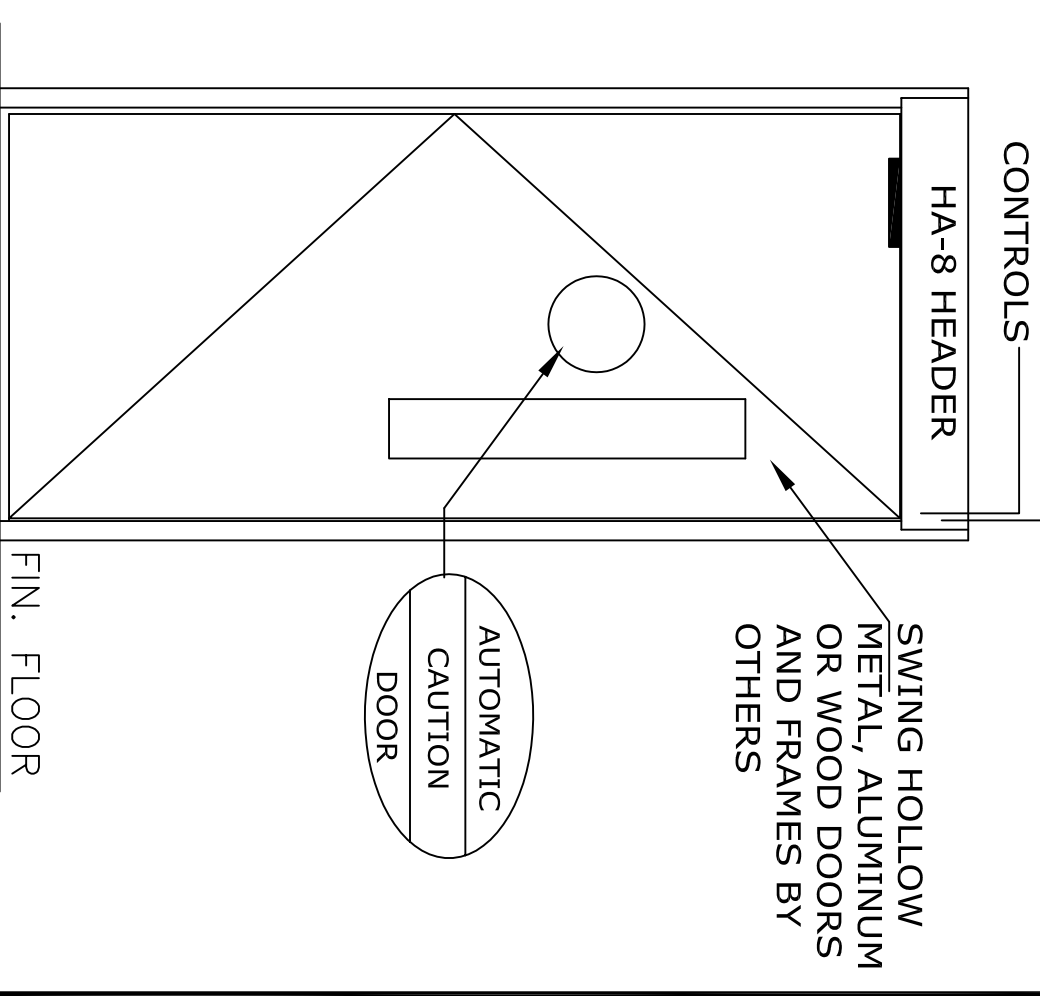

FILLER PLATE AS  
 REQUIRED BY  
 OTHERS

REINFORCEMENT  
 BY OTHERS

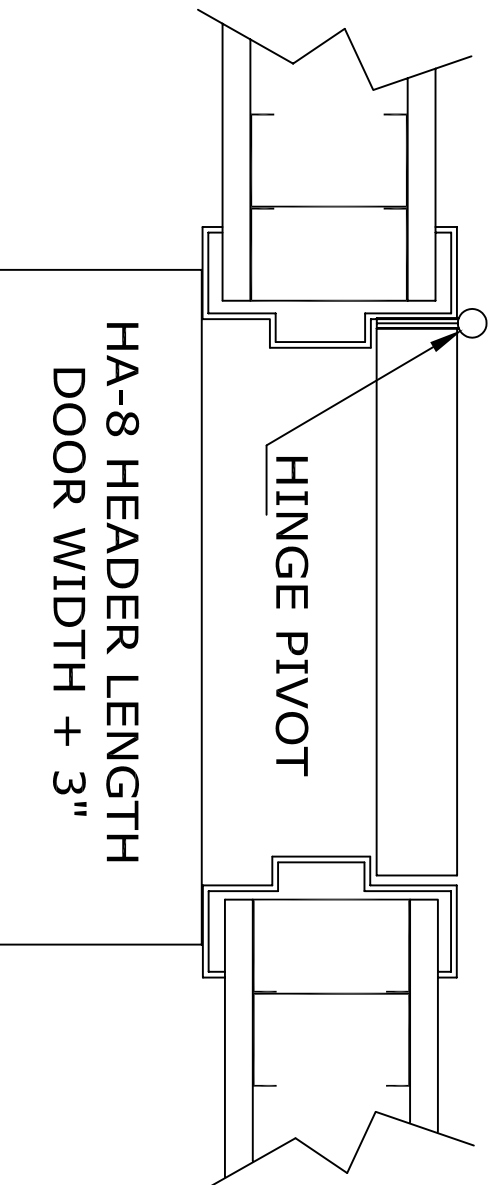
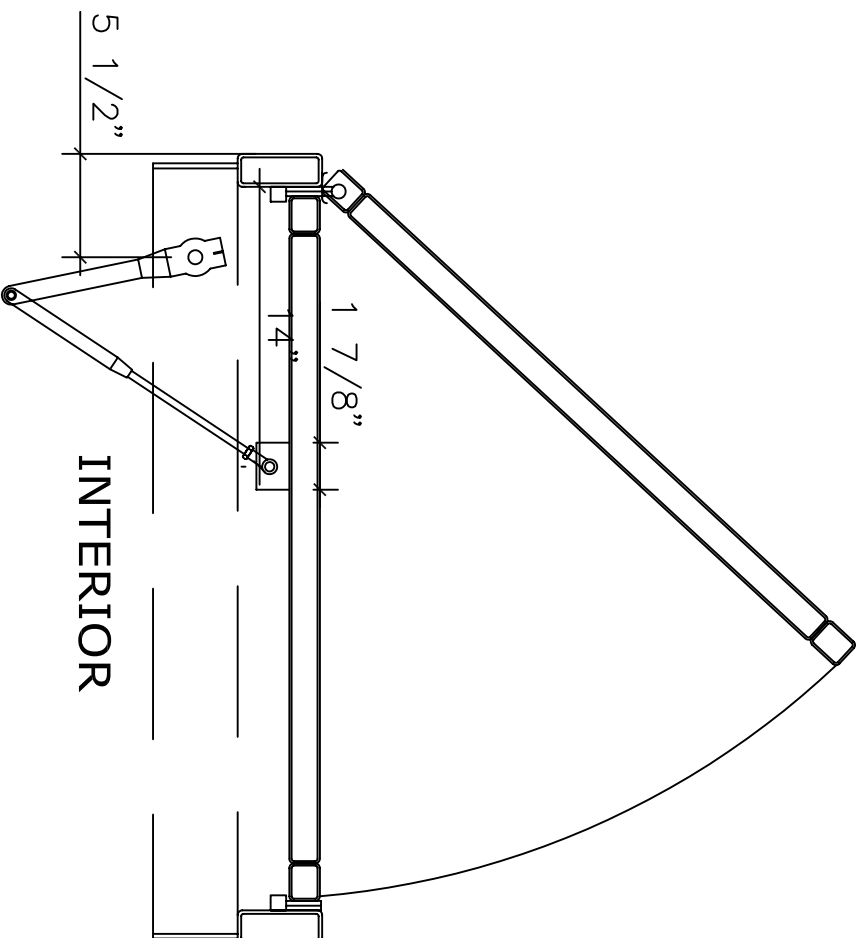
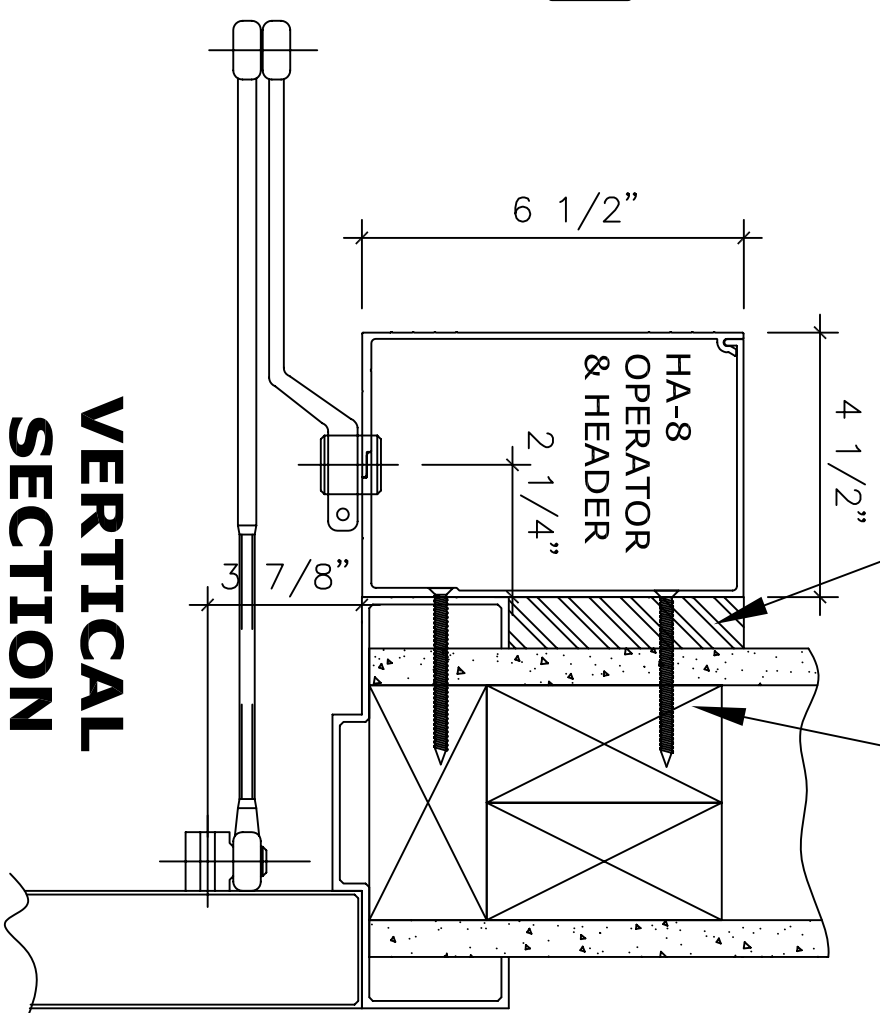

**NOTE:**  
 HUNTER ACCESS TECHNOLOGIES INC. RESERVES  
 THE RIGHT TO CHANGE & IMPROVE ITS  
 PRODUCTS & SPECIFICATIONS WITHOUT NOTICE.



125 KENYON DRIVE  
 SUITE #3  
 LAKEWOOD, NJ 08701  
 TEL: 732-942-6099  
 FAX: 732-942-6033  
 www.hunteraccesstechnologies.com

SHEET TITLE:		SHEET NO.	
ARCHITECT:		<b>2</b>	
CONTRACTOR:		SECTION	
SCALE:	DRAWN BY:	DATE:	<b>HA</b>