

NOTE:
 MANUAL SLIDING DOOR SYSTEM SHALL BE HUNTER "IC-18" AS
 ENGINEERED, MANUFACTURED & ASSEMBLED BY HUNTER ACCESS
 TECHNOLOGIES INC.

STANDARD FINISH: ANODIZED, CLEAR; DARK BRONZE;
 SPECIAL FINISHES ARE AVAILABLE

APPLICATION:
 IC-18-1-FLR. FIXED SIDELITE RIGHT HAND,
 INTENSIVE CARE UNIT SLIDER SYSTEM.

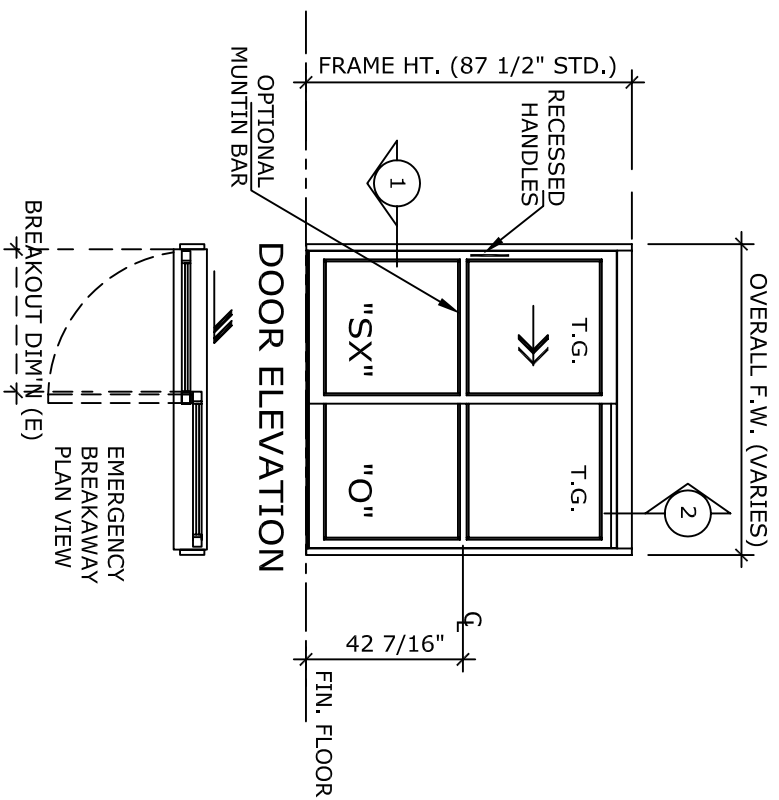

UNIT DESCRIPTION	
HUNTER IC-18-1-FLR	
SX-O: OVERHEAD CONCEALED FIXED SIDELITE R.H. SINGLE SLIDE NARROW STILE MANUAL DOOR SYSTEM. STD. PACKAGE SHALL INCLUDE MANUAL HEADER, FRAME AND DOORS WITH MUNTIN, 4" BOTTOM RAILS WITH CONCEALED SWEEP, BRUSH-PILE WEATHER STRIPPING, EMERGENCY BREAKAWAY, GLAZING GLAZING STOPS FOR 1/4" T.G. AND RECESSED HANDLES. BOTTOM GUIDE IS CONCEALED IN 'J' MOLDING OF FIXED PANEL.	

DOOR TYPE:	OVERALL FRAME WIDTH (A)	ROUGH OPENING WIDTH (B)	EQUAL PANELS WIDTH (C)	NET DOOR OPENING (D)	BREAK OUT DIM'N (E)
IC18-1-FLR-	84"	84 1/2"	41 9/16"	35 1/4"	38 7/8"
FLR-7	84"	84 1/2"	41 9/16"	35 1/4"	38 7/8"
FLR-8	96"	96 1/2"	47 9/16"	41 1/4"	44 7/8"
FLR-9	108"	108 1/2"	53 9/16"	47 1/4"	50 7/8"
KEY (INCHES)	(B-1/2)	(A+1/2)	(A/2-7/16)	(A/2-6 3/4)	(A/2-3 1/8)

REFER TO RELEVANT (LOCAL, STATE, NATIONAL OR AHJ) BUILDING CODE FOR MIN DOOR
 HEIGHT & MIN/MAX WIDTH ALLOWABLE FOR EGRESS REQUIREMENT.

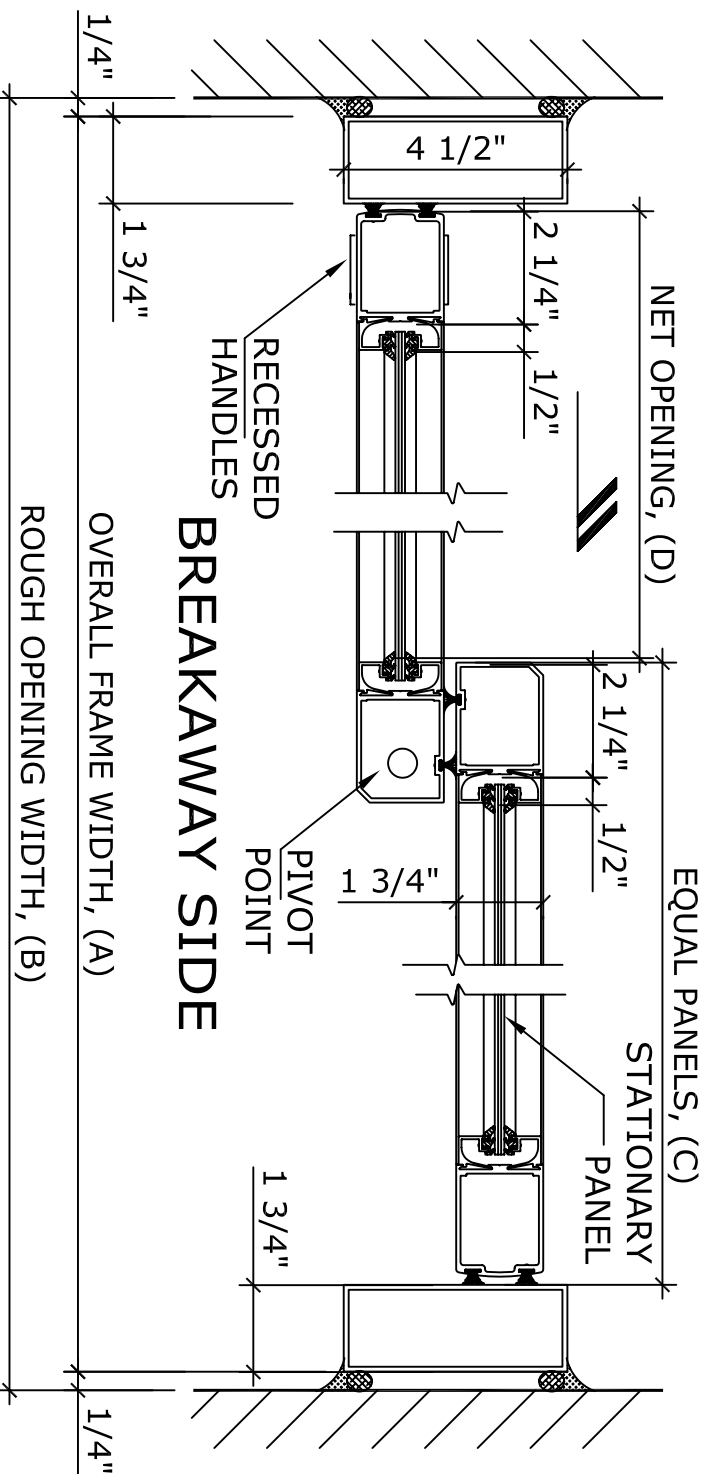

1 HORIZONTAL SECTION

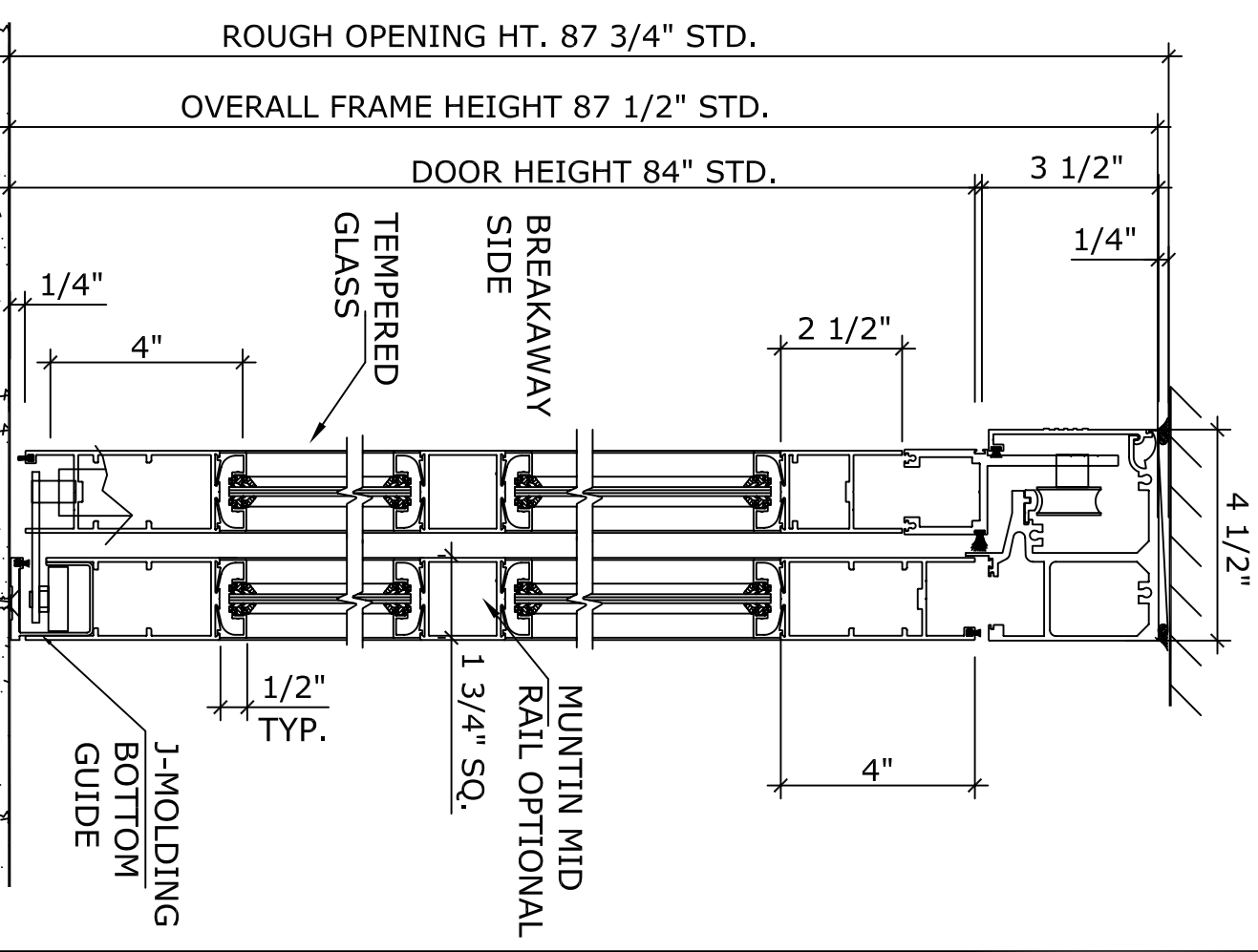

2 VERTICAL SECTION

NOTE:
 HUNTER ACCESS TECHNOLOGIES INC. RESERVES
 THE RIGHT TO CHANGE & IMPROVE IT'S
 PRODUCTS & SPECIFICATIONS WITHOUT NOTICE.

125 KENYON DRIVE
 SUITE #3
 LAKEWOOD, NJ 08701
 TEL. 732-942-6099
 FAX. 732-942-6033
 www.hunteraccesstechnologies.com

SHEET TITLE:		SHEET NO.:	11
ARCHITECT:		SECTION:	IC
CONTRACTOR:		SCALE:	
DRAWN BY:		DATE:	